

*Thank you for selecting a Kennedy as your choice in Professional Tool Storage! For four generations, Kennedy has provided metal products of the highest craftsmanship for the American worker. From humble beginnings to its current status as the premier industrial tool storage line, Kennedy is the leader America trusts.*

*Kennedy tool boxes, handed down from generation to generation, are a constant reminder that there is no substitute for quality. We sincerely appreciate your confidence in us.*



*Kennedy carries a large line of accessories and the enclosed flier can be used for your convenience in locating some of Kennedy's finest. View our website, [www.kennedymfg.com](http://www.kennedymfg.com), and view or download our accessory catalog or full line general catalog. Call us to order or go to our website to locate a Kennedy distributor in your area. While you are there, please visit our Customer Service page and register your Kennedy product. We love to hear from our customers and our Contact page is the perfect place for you to tell us your comments and suggestions or request more information. You can be assured that your request will be individually read and answered. Thank you for choosing Kennedy!*



**LIMITED WARRANTY**

*Kennedy Manufacturing Company products are warranted by Kennedy Manufacturing Co., Van Wert, Ohio, against defects in workmanship or materials under normal use as long as you own the product. This is a lifetime warranty.*

*Kennedy will repair or replace any products which fail to give satisfactory service due to defective workmanship or materials.*

*Kennedy will not warranty any product subjected to abnormal use. Abnormal use includes unreasonable use, misuse, neglect, lack of maintenance or modification.*

**LIMITATION OF LIABILITY**

*To the extent allowable under applicable law, Kennedy's liability for consequential and incidental damages is expressly disclaimed. Kennedy's liability in all events is limited to, and shall not exceed, the purchase price.*

***✻ Register your new Kennedy online at  
[www.kennedymfg.com](http://www.kennedymfg.com) ✻***

# ASSEMBLY, USE AND CARE OF YOUR KENNEDY PRODUCT

To assist you in the assembly, use and care of your new Kennedy tool box, we have compiled the notes below to help you keep your tool box operating like new for many years to come.

## Assembly

**Casters**—Assembly requires flat tip screwdriver and ½" socket or ½" open end wrench.

(2) rigid and (2) swivel with toe brakes. Bolts, lock washers and hex nuts furnished for assembly to cabinet.

Unit with bottom front panel - open bottom drawer, lift and open panel for caster mounting.

Units with full drawers - bottom drawer must be removed for caster mounting. Lay cabinet on its back when mounting casters. Line up caster holes to bottom pan or reinforcement rail and fasten with round head of bolt to the outside.



**Tubular End Handle** —Requires flat tip screwdriver.

Side handle should be mounted on the same end as the swivel casters.

1. Mount end handle on same end as swivel casters.
2. Bracket holes must line up to double set of holes in body. Attach each bracket with (2) ¼" x ½" screws.



## Use

### Drawer & Slide Removal

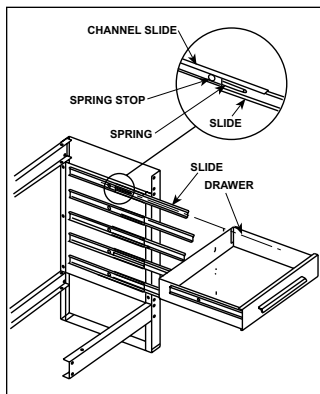

#### I-Beam Friction Slides

**Note: Unload drawer prior to drawer removal.**

To remove drawers and slides, pull drawer all the way out. Insert screwdriver and lift drawer slide spring out and down on both sides and remove the drawer. To insert drawers, reverse the process.

#### Ball Bearing Slides

**Note: Unload drawer prior to drawer removal.** To remove drawers and slides, pull drawer all the way out, depress clear lever on each slide, removing drawer at the same time. To re-install drawer, insert guides on drawer sides into slides and firmly close drawer all the way.

### Lock Removal



1. Insert flat tip screwdriver between lock and retainer clip. Pry clip away from lock.
2. To Assemble: Insert lock with cam in upright position and force retainer clip over lock.

Roller Cabinets—rod with cam must be in upright position in cabinet. Turn key in lock counter clockwise and insert into cabinet while aligning the rod end into back of lock. Attach retainer clip over lock.

**NOTE: Record key number and place in safe keeping.**

## Care

**Slides**—A light coating of oil on the friction slide will preserve and provide easy movement of parts.

**Cleaning of Finish**—Your Kennedy wrinkle finish unit can be cleaned periodically with WD-40 or Murphy's Oil Soap. The smooth finish units should be cleaned with a soft cloth, dampened with warm water.