

*Kennedy Manufacturing Company  
520 E. Sycamore Street • Van Wert, OH 45891  
Phone 800-413-8665 • FAX 419/238-5644  
www.kennedymfg.com*

---

## ***Versa-Bench Model 4810 Assembly Instructions***

---

### ***Style No. 4810***

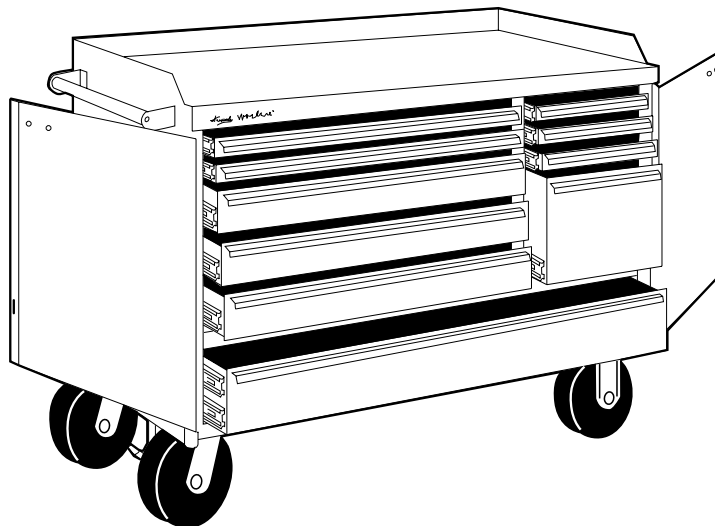

### ***BEFORE ASSEMBLY OF YOUR VERSA-BENCH®***

*Check carefully to ensure that all parts listed on the reverse side are included. If any are missing, please call 800-413-8665 and ask for the Sales Dept. Do not discard packing material until assembly is complete.*

### ***TOOLS REQUIRED***

*Flat tip screw driver  
7/16" Open end wrench or socket wrench  
3/8" Open end or socket wrench*

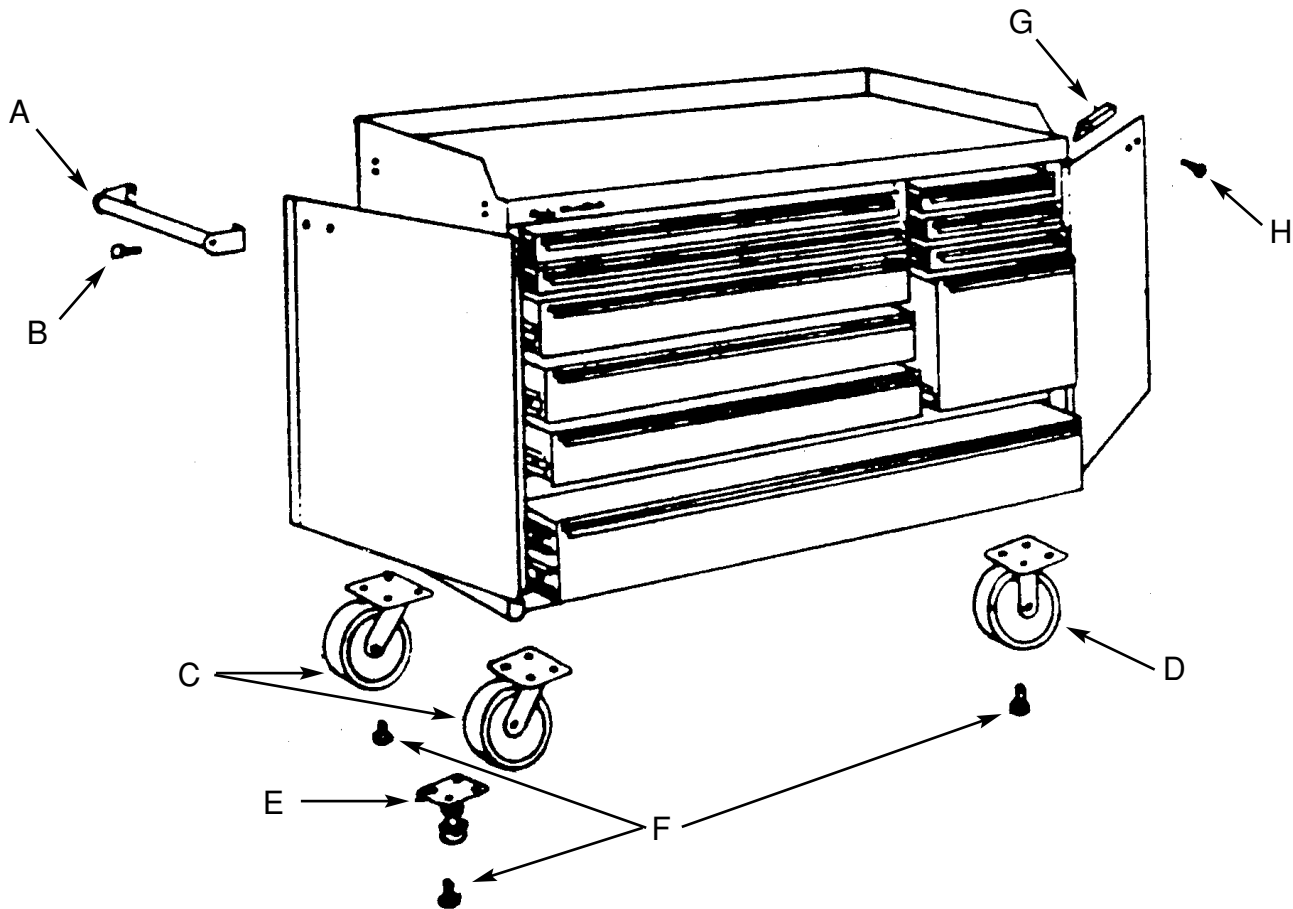

QTY	KEY	PARTS DESCRIPTION
1	(A)	Chrome Plated Push Handle
4	(B)	1/4" x 3/4" Hex Head Bolts
2	(C)	8" x 2" Swivel Casters
2	(D)	8" x 2" Rigid Casters
1	(E)	Floor Lock
20	(F)	3/8" x 3/4" Hex Head Bolts
2	(G)	"L" Shaped Aluminum Door Handle
4	(H)	#8-18 x 3/8" Sheet Metal Hex Screws

1. Fasten chrome push handle (A) to end of bench as shown using (4) 1/4" x 3/4" hex head bolts (B).
2. Lift bench with a fork lift or lay on its back on shipping carton to install casters and floor lock. Remove bolts from wood shipping blocks from bottom of the Versa-Bench.
3. Fasten swivel casters (C), floor lock (E) and at opposite end attach rigid casters (D) with (4) each 3/8" x 3/4" hex bolts (F) to weld nuts in bottom. Carefully, set bench upright. **Note:** Swivel casters and floor lock should be located at same end of bench as chrome push handle.
4. Fasten door handles (G) to each door with (4) 3/8" sheet setal hex screws (H).