

TUBULAR, HIGH-SECURITY LOCK

REMOVAL PROCEDURES:

To drill out lock, follow steps:

1. Center punch the center of the lock deeply for drill bit.
2. Drill pilot hole using 5/32 drill bit, drill 7/8" depth thru lock. Pre-mark drill bit to the depth to prevent damage to the cam rod located at end of lock.
3. Using 1/2-inch drill bit, drill 7/8" depth into lock. You may need to open the hole with drill bit to cut out spring and pins. NOTE: Cam rod may drop off from back of the lock. Follow step 4.
4. Use flashlight and look between top pan and top drawer to back center of cabinet. You will see the internal locking system. Use 1/8" round wire with 1/2 inch, 90 degree formed angle at one end, reach into the cabinet between the top pan and the top drawer and disengage the cam rod from the tie bar. Insert formed angle into the compression spring and lift upward and open the top drawer.
5. Remove the top drawer from the cabinet. Remove the c-clip from the back of lock with screwdriver. Remove lock.

ASSEMBLY PROCEDURES:

To assemble lock follow steps:

- 1) Place round end of the cam rod into the tie bar while locating the cam rod bar into the bracket located on the top pan.
- 2) Rotate the cam in the bar to upright position. This is the unlocked position.
- 3) Insert lock into top pan. Rotate key counter clockwise. Align the cam rod into the back of the lock and turn key counter clockwise to the locked position. If locking system rotates properly, attach the c-clip to the back of the lock to hold it in place.

Unlock the drawers and re-install the drawers that were removed.

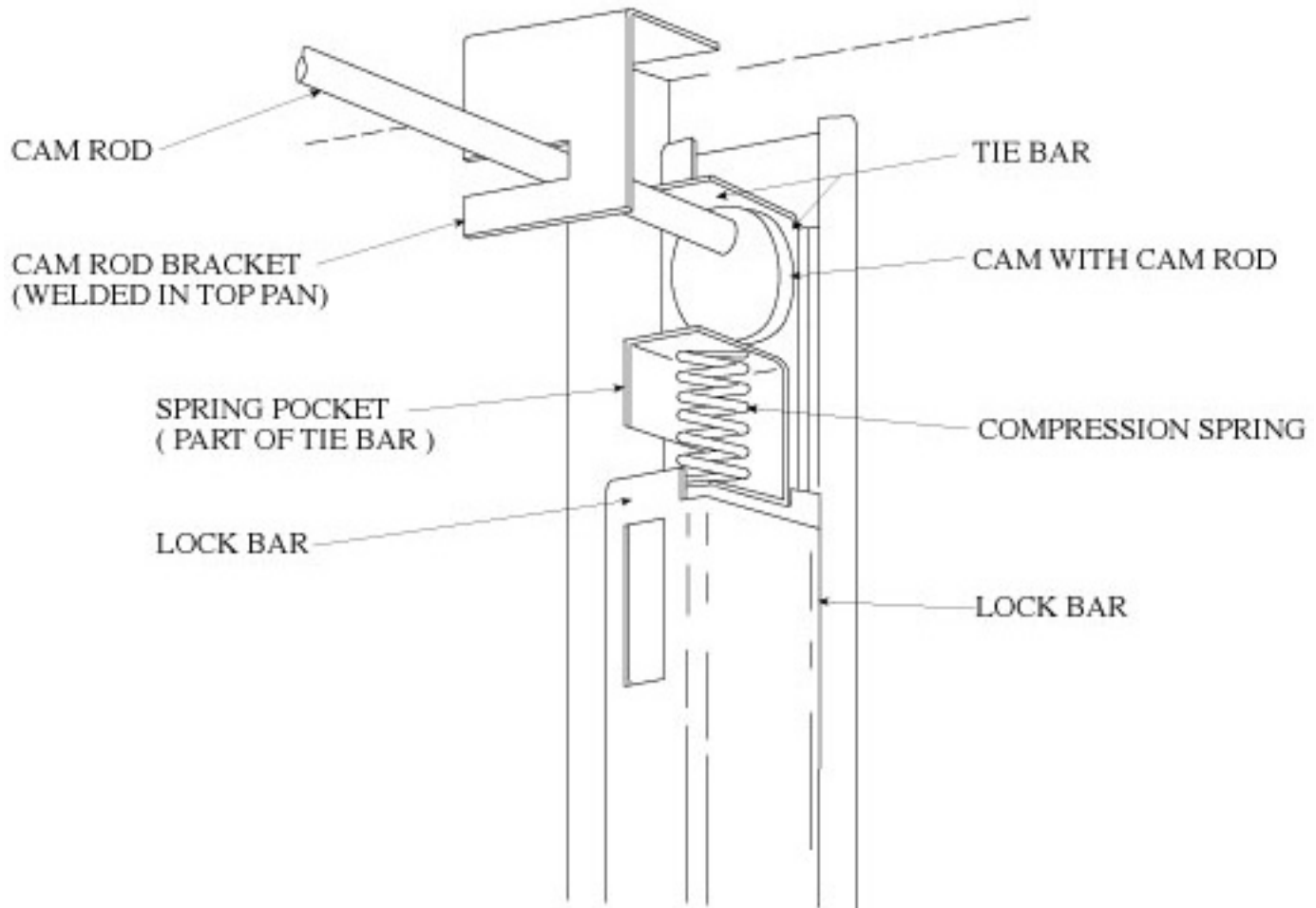

If cabinet is locked, a 3/8" or 1/2" drill bit should be used to drill into the center of the lock.

Drill back through the barrel of the lock to the cam rod tip. If lock is still secure, drill up into the side wall of the barrel.

The cam rod tip should drop down or can be slightly forced out of the barrel. Using a 1/4" rod with flat tip, shove the cam rod to the left out of the bracket. While the 1/4" rod is inserted through the lock barrel, insert the flat tip of the rod into the spring pocket and raise the rod up forcing the lock bar to release. Remove top two drawers while the lock bar is in the raised position. Complete the removal of the drilled out lock.

INSTALLING THE NEW CAM ROD ASSEMBLY

Prior to installing the new lock, rotate the key counterclockwise until it stops and remove the key.

With the roller cabinet unlocked (CAM IN UP POSITION), slide the lock onto the cam shaft. Insert the key and make sure it works freely prior to installing the lock retainer clip.