

Thank you for purchasing this Kennedy product. We produce quality built products for value conscious users. We welcome any comments or suggestions you may have, just call or write the address below. We hope you will continue to find Kennedy the most complete source for your tool storage needs.

Kennedy[®]

Since 1911

Assembly Instructions

Style No. 50050 Toolboard Braces

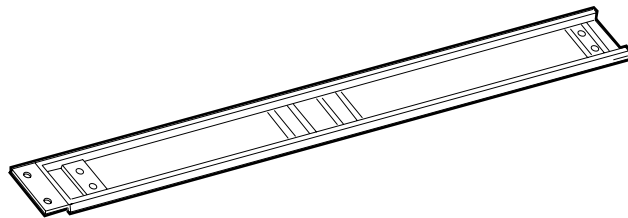

50050 Kit Contains:

- (1) 50050 Toolboard Brace
- (1) Hardware Packet

Step one:

- a. Remove top drawers as needed to provide ample working space from inside the cabinet.
- b. Place bracket to outside rear corner of cabinet and transfer punch hole pattern into top and rear of cabinet.
- c. Drill 5/16 dia. holes at transfer locations .
(Note: Screw holes are large for adjustment. Washers are provided in Hardware Packet.)
- d. Use screws from Hardware Packet to bolt into place.

Step two:

- a. Repeat step one on opposite side of cabinet.

Step three:

- a. Bolt panels to brackets. Note: Washers are needed on panel holes aligned with mounting bracket slots.

Step 1

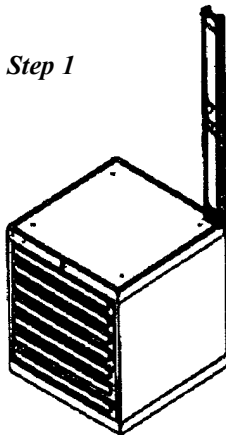

Step 2

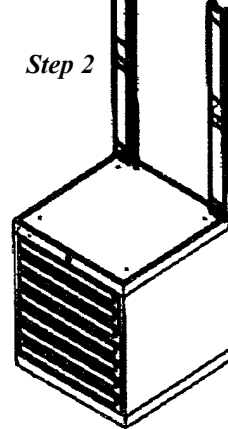

Step

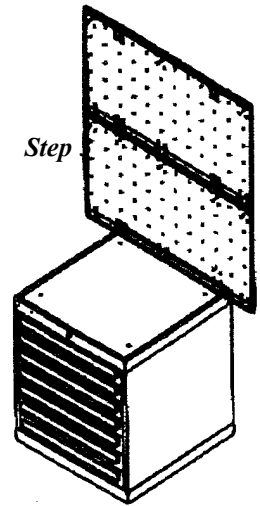

Step 1

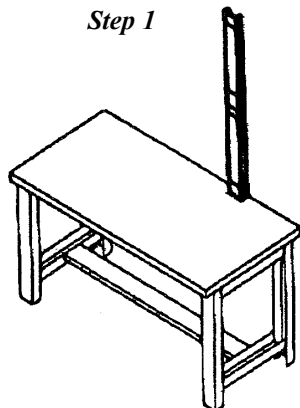

Step 2

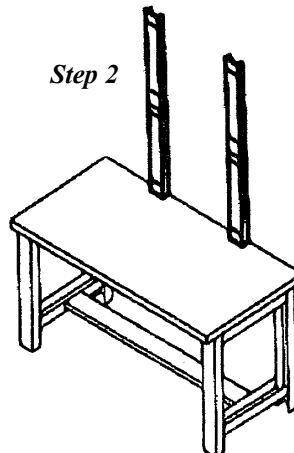

Step 3

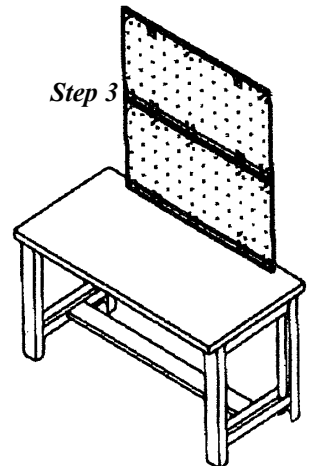

For wood tops, drill 3/16 dia. holes at transfer locations.

(Note: Lag screws are to be used in all wood applications.)