

ELECTRICAL PANEL ASSEMBLY

ELECTRICAL PANEL ASSEMBLY SUPPLY LIST

PARTS DESCRIPTION

Lag Screws

ASSEMBLY:

1. Remove required knock outs from electrical panel.
2. Align electrical panel to bottom front edge of work top. Mark mounting holes pattern to the top. Pre-drill 3/16" x 3/4" starter holes for lag screws.
3. Align electrical panel to the top and attach using lag screws.

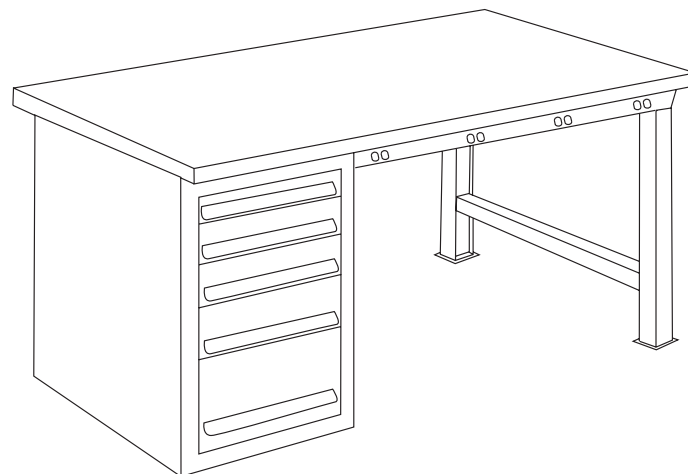

SIDE/BACK RETAINER ASSEMBLY

SIDE/BACK RETAINER ASSEMBLY SUPPLY LIST

PARTS DESCRIPTION

(14) 14 x 5/8" Screws

ASSEMBLY:

1. Turn wood top upside down and place side and back retainers.
2. Fasten with 14 x 5/8" screws.
3. Attach wood top to cabinet and/or legs.

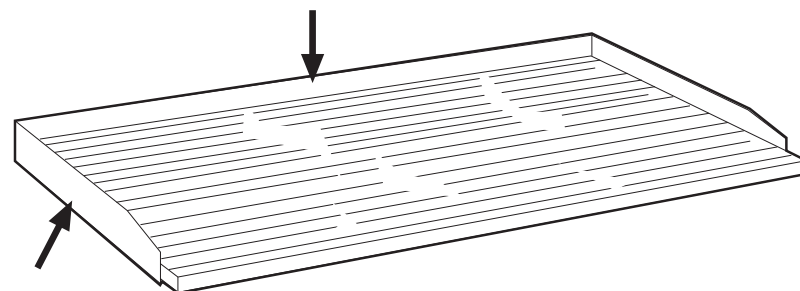

RISER ASSEMBLY

RISER ASSEMBLY SUPPLY LIST

PARTS DESCRIPTION

(6) Hex Screws, 5/16" x 1"

(6) 5/16" x 3/4" x 5/64" Washers

(8) 1/4" x 20 Hex Nuts

(8) 1/4" Lock Washers

(8) 1/4" x 20 x 1/2" Pan Head Slotted Screws

(8) Washers

ASSEMBLY:

1. Attach riser top to sides using (2) each Pan Head Screws, 1/4" Lock Washers and 1/4" x 20 Hex Nuts.
2. Align riser on wood top and fasten with 5/16" x 1" Hex Screws and 5/16" x 3/4" x 5/64" Washers, (3) on each end.

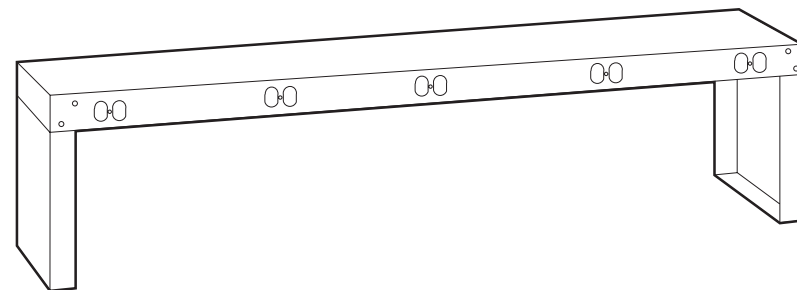

Thank you for purchasing this Kennedy product. We produce value-built products for value conscious users. We welcome any comments or suggestions you may have. Just call or write the address below. We hope you will continue to find Kennedy the most complete source for your tool storage needs.

Kennedy
Since 1911

MODULAR WORK STATION ASSEMBLY INSTRUCTIONS



BEFORE ASSEMBLY OF YOUR WORK STATION

Check carefully to ensure that all parts listed below are included. If any are missing, please call 1-800-413-8665 and ask for the Sales Department. Do not discard packing material until assembly is complete.

TOOLS REQUIRED

7/16" Open End Wrench or Socket Wrench—Main Assembly

1/2" Open End or Socket Wrench—Steel Top Assembly

Drill and 3/16", 5/16" Drill Bit—Top Pilot Hole—Wood Top Assembly

24" Combination Square

ASSEMBLY OF CABINET AND LEG TO WORK SURFACE

CABINET ASSEMBLY SUPPLY LIST

<u>QTY</u>	<u>PART DESCRIPTION</u>
(4)	Hex Head Wood Screws
(4)	Washers

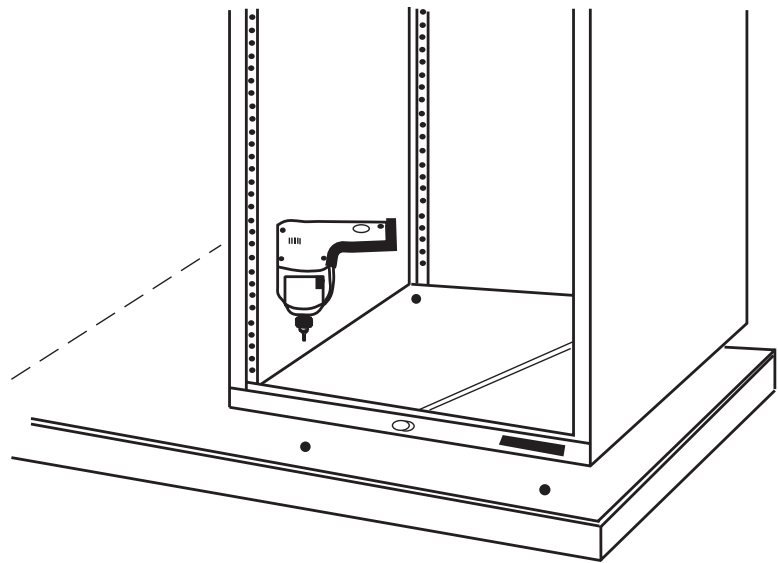

LEG ASSEMBLY SUPPLY LIST

<u>QTY</u>	<u>PART DESCRIPTION</u>
(6)	Hex Lag Screws
(6)	Washers

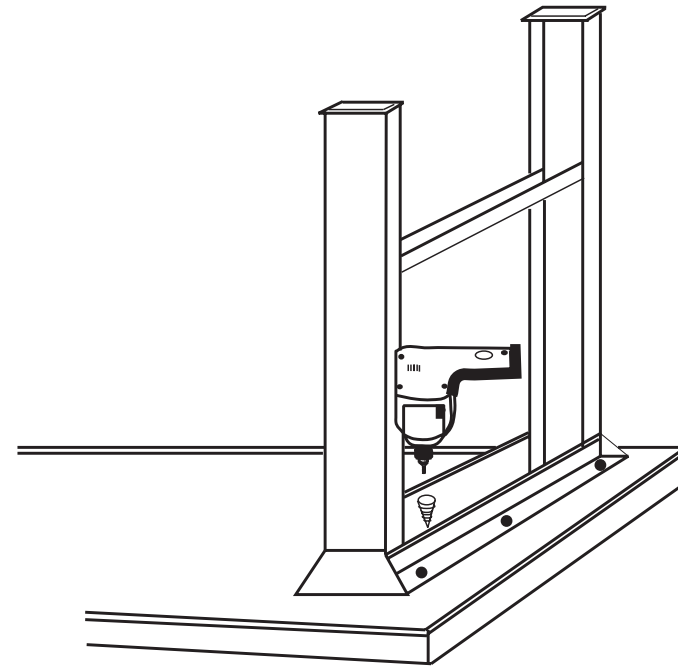

ASSEMBLY:

NOTE: Remove drawers from cabinet before assembly. Follow listed assembly procedures for combination of two cabinets, two legs or cabinet and leg.

1. Place a piece of cardboard on the floor and lay the bench top on it with finished surface face down.
2. Place cabinet housing upside down on the bench top. Position cabinet housing to allow desired overhang from front to back and sides. Recommend enough overhang at front to allow key in unlocked position to be in alignment with front edge of the top.
3. Mark mounting hole pattern to the top. Pre-drill 3/16" x 3/4" starter hole for lag screws.

LEG ASSEMBLY:

5. Locate work bench leg approximately 2" in from end of bench top. Mark mounting hole pattern to the top. Pre-drill 3/16" x 3/4" starter hole for lag screws. Align bench leg and attach using (6) washers and (6) lag screws.

FOOT REST ASSEMBLY

FOOT REST ASSEMBLY SUPPLY LIST

<u>QTY</u>	<u>PART DESCRIPTION</u>
(4)	1/4-20 Screws
(4)	Washers
(4)	Nuts

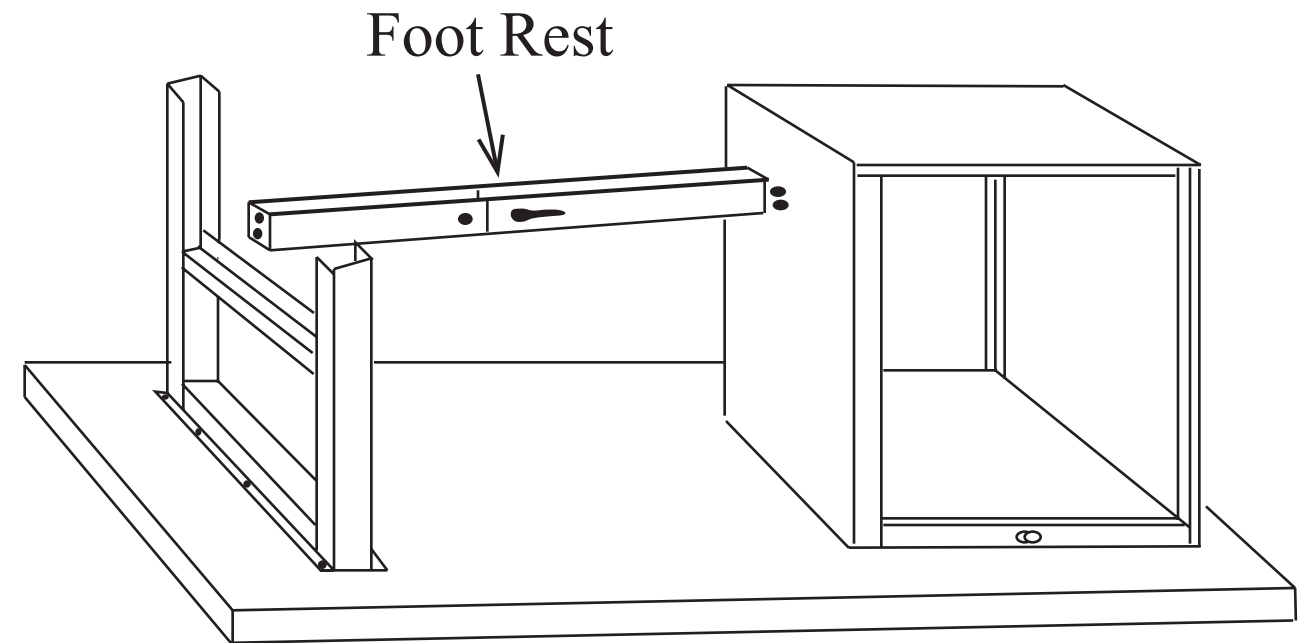

ASSEMBLY:

NOTE: Assembly of (2) cabinets, (2) legs or combination of cabinet and leg, must be completed before foot rest assembly.

1. Using 24" combination square measure distance from top to piercing location in leg cross support, for foot rest attachment to cabinet side.
2. Attach foot rest to leg cross support using (2) 1/4-20 screws, washers and nuts.
3. Extend and align unattached end of foot rest to cabinet side, using 24" combination square, place blade against cabinet side with bead on foot rest. Check for horizontal and vertical levelness, mark mounting hole pattern to cabinet side.

Drill (2) 5/16" diameter holes. Extend foot rest to cabinet wall and align to holes. Attach using (2) 1/4-20 screws, washers and nuts.

Note: Attaching foot rest between two legs, follow step #2.

Attaching foot rest between two cabinets, measure to desired height and complete assembly required in step #3.