



***Kennedy Manufacturing Company
520 E. Sycamore Street
Van Wert, OH 45891-1377
Phone 1-800-413-8665
FAX 419-238-5644***

WORK STATION DOOR ASSEMBLY INSTRUCTIONS

STYLE NO. D026

BEFORE ASSEMBLY OF YOUR WORK STATION

Check carefully to ensure that all parts listed on the reverse side are included. If any are missing, please call 1-800-413-8665 and ask for the Sales Department. Do not discard packing material until assembly is complete.

TOOLS REQUIRED

*Flat Tip Screwdriver—Main Assembly
7/16" Open End Wrench or Socket Wrench*

To order an additional door, refer to your Kennedy Catalog.

Qty.	Key	Parts Description
1	(A)	Door
1	(B)	Latch Bar
2	(C)	1/4" x 1/2" Bolt (one way entry)
2	(D)	1/4" x 1/2" Bolt
4	(E)	Lock Washer, Hex Nut

ASSEMBLY INSTRUCTIONS

Door Assembly Covering Work Station Shelves

1. Attach door assembly (A) to side (F), using (2) 1/4" one way entry bolts (C), lock washers and hex nuts (E).
See Sketch #1.
2. Attach latch bar (B) to center support (G), using (2) 1/4" bolts (D), lock washers and hex nuts (E). Adjust latch bar for locking alignment with door in closed position before tightening hex nuts.
See Sketch #1.

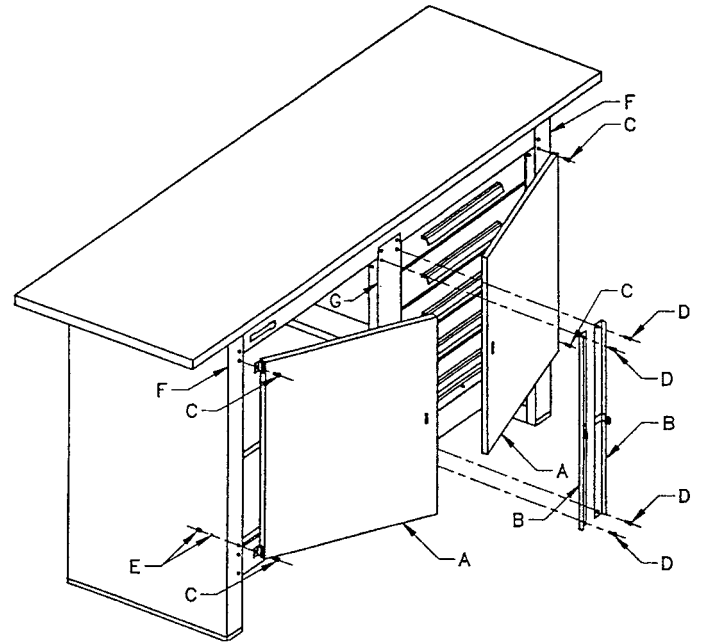

Door Assembly Covering Work Station Drawers

1. Remove (2) 1/4" bolts from side (F). **See Sketch #1.**
2. Attach door assembly (A) to side (F), using (2) 1/4" bolts (D), lock washers and hex nuts (E). Adjust latch bar for locking alignment with door in closed position before tightening hex nuts.
See Sketch #1.

Door Assembly Covering Tool Stand Drawers

1. Attach door assembly (A) to side (F), using (2) 1/4" one way entry bolts (C), lock washers and hex nuts (E). **See Sketch #2.**
2. Remove (2) 1/4" bolts from side (F). **See Sketch #2.**
3. Attach latch bar (B) to side (F), using (2) 1/4" bolts (D), lock washers and hex nuts (E). Adjust latch bar for locking alignment with door in closed position before tightening hex nuts.
See Sketch #2.

